



CII

TE Internal #: 1-1617004-7

Full-Size Relays, 2 Form C, DPDT, 2 C/O, Silver Cadmium Oxide, 26.5 VDC Input, 10 A, 26.5 VDC Coil Voltage, 300 Ω Coil Resistance

[View on TE.com >](#)

Relays, Contactors & Switches > Relays > Mil-Aero Relays > Full-Size Relays



Full-Size Relay Contact Arrangement: **2 Form C, DPDT, 2 C/O**

Contact Base Material: **Silver Cadmium Oxide**

Full-Size Relay Input Voltage: **26.5 VDC**

Full-Size Relay Contact Current Rating: **10 A**

Coil Voltage: **26.5 VDC**

**Features**

**Product Type Features**

Enclosure Type	Hermetically Sealed
Coil Latching	Without
Product Type	Relay
Relay Type	Military/Aerospace High Performance
MOSFET Driver	Without

**Configuration Features**

Transistor Driver	Without
-------------------	---------

**Electrical Characteristics**

Actuating System	DC
Vibration	20G's, 10 – 2000Hz
Coil Magnetic System	Non-Polarized, Monostable
Shock	50G's, 11ms
Coil Suppression Diode	Without
Coil Polarity Protection Diode	Without
Full-Size Relay Input Voltage	26.5 VDC
Coil Voltage	26.5 VDC
Full-Size Relay Coil Resistance	300 Ω
Full-Size Relay Coil Power Rating (DC)	2340 mW



Coil Power Measurement	Milliwatts
------------------------	------------

Full-Size Relay Contact Switching Voltage (Max)	28 VDC
---	--------

### Contact Features

Full-Size Relay Contact Arrangement	2 Form C, DPDT, 2 C/O
-------------------------------------	-----------------------

Contact Base Material	Silver Cadmium Oxide
-----------------------	----------------------

Full-Size Relay Contact Current Rating	10 A
--	------

### Termination Features

Termination Type	Solder Hook Terminals
------------------	-----------------------

### Mechanical Attachment

Full-Size Relay Mounting Type	Chassis Mount
-------------------------------	---------------

### Usage Conditions

Operating Temperature Range	-70 – 125 °C
-----------------------------	--------------

## Product Compliance

[For compliance documentation, visit the product page on TE.com>](#)

EU RoHS Directive 2011/65/EU	Not Compliant
------------------------------	---------------

EU ELV Directive 2000/53/EC	Not Compliant
-----------------------------	---------------

China RoHS 2 Directive MIIT Order No 32, 2016	Restricted Materials Above Threshold
---	--------------------------------------

EU REACH Regulation (EC) No. 1907/2006	Current ECHA Candidate List: JUNE 2022 (224) Candidate List Declared Against: JAN 2022 (223) SVHC > Threshold: Not Yet Reviewed
--	--

Halogen Content	Not Yet Reviewed for halogen content
-----------------	--------------------------------------

Solder Process Capability	Not lead free process capable
---------------------------	-------------------------------

#### Product Compliance Disclaimer

This information is provided based on reasonable inquiry of our suppliers and represents our current actual knowledge based on the information they provided. This information is subject to change. The part numbers that TE has identified as EU RoHS compliant have a maximum concentration of 0.1% by weight in homogenous materials for lead, hexavalent chromium, mercury, PBB, PBDE, DBP, BBP, DEHP, DIBP, and 0.01% for cadmium, or qualify for an exemption to these limits as defined in the Annexes of Directive 2011/65/EU (RoHS2). Finished electrical and electronic equipment products will be CE marked as required by Directive 2011/65/EU. Components may not be CE marked. Additionally, the part numbers that TE has identified as EU ELV compliant have a maximum concentration of 0.1% by weight in homogenous materials for lead, hexavalent chromium, and mercury, and 0.01% for cadmium, or qualify for an exemption to these limits as defined in the Annexes of Directive 2000/53/EC (ELV). Regarding the REACH Regulations, TE's information on SVHC in articles for this part number is still based on the European Chemical Agency (ECHA) 'Guidance on requirements for substances in articles' (Version: 2, April 2011), applying the 0.1% weight on weight concentration threshold at the finished product level. TE is aware of the European Court of Justice ruling of September 10th, 2015 also known as O5A (Once An Article Always An Article) stating that, in case of 'complex object', the threshold for a SVHC must be applied to both the

product as a whole and simultaneously to each of the articles forming part of its composition. TE has evaluated this ruling based on the new ECHA "Guidance on requirements for substances in articles" (June 2017, version 4.0) and will be updating its statements accordingly.

## Compatible Parts

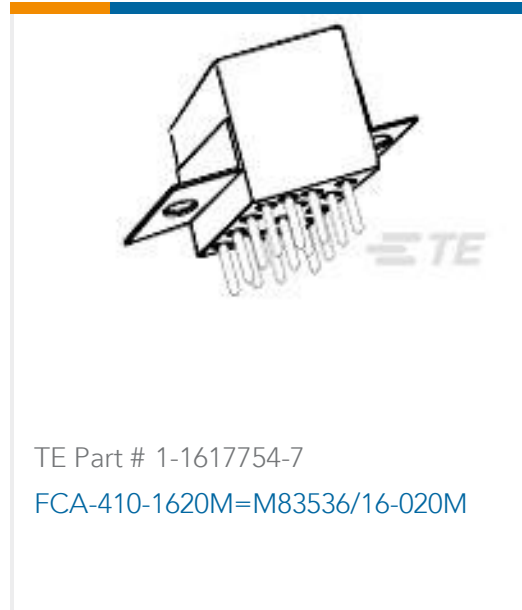

## Documents

### Product Drawings

[B07D112BC4-0007 = MS27245-1](#)

English

### Datasheets & Catalog Pages

[5-1773450-5\\_sec1\\_07](#)

English

[RELAY](#)

English